

ALFALINE

Technical data pages by Formrack

Alfaline 19" 560 mm Wall Mounted Cabinet

FORMRACK®



General Features

- Alfaline cabinets have three side openable, lockable and easily removable covers.
- The side covers are made by DKP sheet and the front side is made by 4 mm thick, impact-resistant, tempered and smoked-colored glass which is supported by metal frames.
- The rear cover is made by high strength DKP sheet that provides high strength with holes for wall mounting.
- The frame and corner profiles have screwed structure at the interior surface
- Ventilation can be provided by cooling units with 1 or 2 fans.
- 7U , 9U , 12U , 16U and 20U height options.
- There are four 19" mounting profiles which can be adjusted in depth according to the need in the cabinet
- Mounting profiles have U markings that facilitate the mounting process.
- At the bottom part of the cabinets, there is a sliding and dust-protected brushed cable entry. These entries are available in three locations, from bottom to top.
- Painted by impact-resistant,high strength, electrostatic Ral 7035 gray.
- All test procedures have been carried out and has RoHS, CE, EN 61587-1 standards.

Technical Descriptions

Dimensions W*D	: W:553 mm D:560 mm
Available U - Sizes	: 7U / 9U / 12U / 16U / 20U
Paint Type	: Electrostatic powder paint
Standarts	: In accordance with the standard TS EN IEC 61587-1: 2022 / ISO9001-2015 / ISO14001-2015 / ISO 45001-2018 / ISO 27001:2017 / RoHS / UL 2416
Material	: Sheet Steel, DIN EN 1030-99 / DC-01 6112 / DC-7122
Load Carrying Capacity	: 120kg / 2 64.55lbs
IP rating	: IP20
Available Colors	: Ral 7035 Light Gray / Ral 9005 Black (Contact your sales representative for different colors)

ALFALINE

FORMRACK

Address: Akcaburgaz Mah. 592. Sokak No:10 B Blok 34522 Esenyurt - Istanbul - Türkiye
T: +90 212 565 56 50 / F: +90 212 567 40 46 www.formrack.com / sales@formrack.com

ALFALINE

Technical data pages by Formrack

Alfaline 19" 560 mm Wall Mounted Cabinet

FORMRACK®

Exploded View

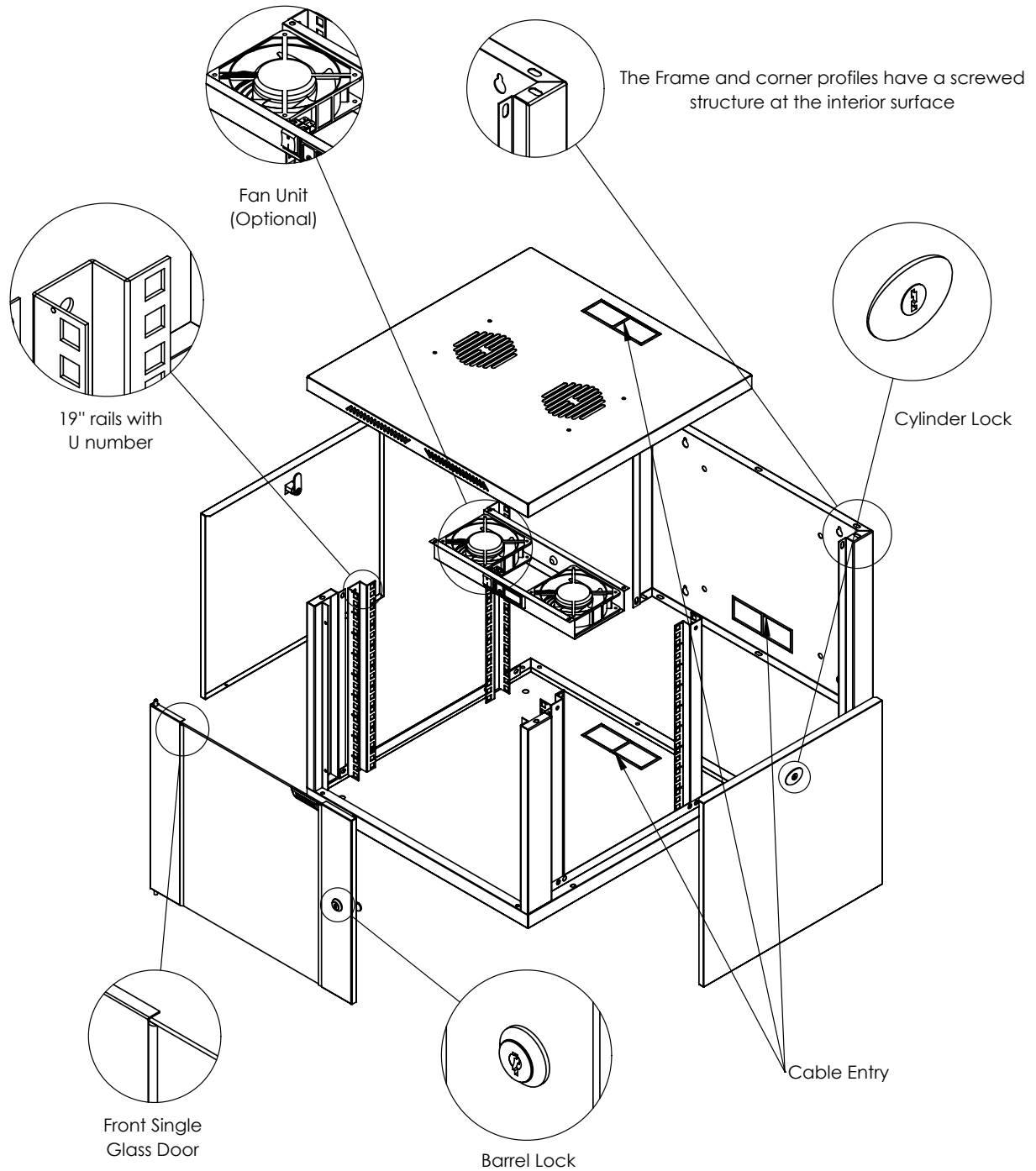

ALFALINE

FORMRACK

Address: Akcaburgaz Mah. 592. Sokak No:10 B Blok 34522 Esenyurt - Istanbul - Türkiye
T: +90 212 565 56 50 / F: +90 212 567 40 46 www.formrack.com / sales@formrack.com

ALFALINE

Technical data pages by Formrack

Alfaline 19" 560 mm Wall Mounted Cabinet

FORMRACK®

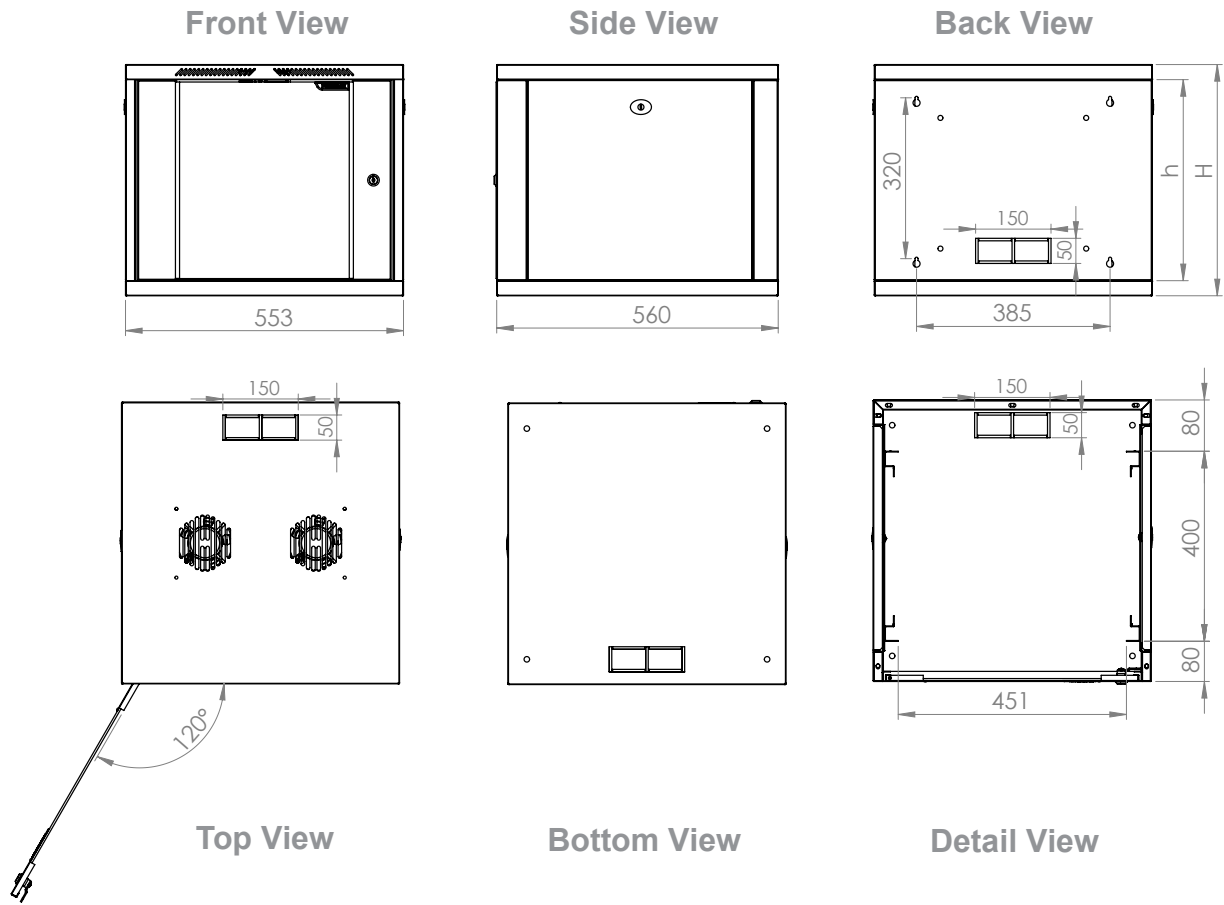

Product Number	Product Name	Dimensions (WxDxH) (mm)	U	H (mm)	h (mm)	Weight (kg)
FORM ALFA-7U560	7U 560 ALFALINE WALL MOUNTED CABINET	553x560x371	7	371	314	16
FORM ALFA-9U560	9U 560 ALFALINE WALL MOUNTED CABINET	553x560x460	9	460	403	17
FORM ALFA-12U560	12U 560 ALFALINE WALL MOUNTED CABINET	553x560x593	12	593	536	22
FORM ALFA-16U560	16U 560 ALFALINE WALL MOUNTED CABINET	553x560x771	16	771	714	29
FORM ALFA-20U560	20U 560 ALFALINE WALL MOUNTED CABINET	553x560x949	20	949	892	35

ALFALINE

FORMRACK

Address: Akcaburgaz Mah. 592. Sokak No:10 B Blok 34522 Esenyurt - Istanbul - Türkiye
 T: +90 212 565 56 50 / F: +90 212 567 40 46 www.formrack.com / sales@formrack.com

STANDARDS

PROTECTION INDEX

- IP20 According to TS 3033 EN 60529
- IP20 :Rigid test rod diameter of 12 mm, 80 mm long (as specified by the standard) is pushed against any openings of the enclosure with the force of 10N

MECHANICAL PERFORMAMANCE

- EN 61587-1 5.2.1 / 5.2.3
- Static mechanical load test (Performance level SL06)
- Resonance point detection test IEC 60068-2-6
- Rolling Test (TS EN IEC 61587-1)
- Vibration test (IEC 60068-2-6)
- Shock test IEC 60068-2-27)
- Permissible load carrying capacity : 1200kg

CLIMATIC TESTS (Performance level C2)

- Cold (IEC 60068-2-1) Temperature of the exposure: -25°C +/-3°C
- Dry heat (IEC 60068-2-2) Temperature of the exposure: +70°C +/-2°C
- Damp heat cyclic (IEC 60068-2-30)

INDUSTRIAL ATMOSPHERE (Performance level A2)

- Sulphur dioxide test and hydrogen sulphide test IEC 60068-2-42, IEC 60068-2-43, IEC 60068-2-49

GROUNDING CONTINUITY

EN 61587-1 / EN 61010-1

The continuity of the protection circuit is in accordance with the standard regulations, measured resistance was less than 0.1 Ohm.

SHEET METAL: TS EN ISO 9001:2008; TS EN 10130 :2006; DIN EN 1030- EQV; BS EN 1030-EQV; NF A36-401.

ELECTROSTATIC POWDER PAINT: ISO 9001:2015 ASTM D523; ASTM D2794; DIN EN ISO 2811-1; ASTM D1186/D1400; Ral:9005 or Ral:7035.

VENTILATION UNITS (Fan Unit) TS EN 62368-1:2020 — AC:2020 — A11:2020

TEMPERED SAFETY GLASS " EN 12150 – 2 Glass, Tempered, secure " Mechanical strength test result: Bending strength minimum 120 N/ mm²

CONNECTION COMPONENTS (screw, nut, washer etc.)" TS EN ISO 7045; TS EN ISO 4032; RoHS IEC 62321 "

WHEEL SET " TS EN 12532 , TS EN 12533 , RoHS IEC 62321:2008"

LOCKS SYSTEMS "DIN-EN ISO 1043-1 PA6 GFR 30; DIN-EN 1774-ZnAl4Cu1.